



# RTS 85

Transom concealed  
door closer



Ironmongery, Curtain Rails, Blinds, Flooring,  
Carpets, Automatic Sliding & Swing Doors,  
Movable Partitions Renovations & much more

☎ 0722 493 359 / 0726 399 819

✉ [info@nextcraftke.com](mailto:info@nextcraftke.com)

📍 Gate No. 95A  
Limuru Road, Parklands.

🌐 [www.nextcraftke.com](http://www.nextcraftke.com)

## Disappears into the frame

**Ideal for shopfitting. For both double and single action doors. Elegant, versatile, practical and quality assured.** The DORMA RTS 85 offers a solution for installations where door control must be provided without disturbing the aesthetic appearance of the door. The majority of preparation can be

accomplished by the fabricator prior to installation, leaving minimal on-site work. A complete line of accessories is available to accommodate virtually any door and frame configuration.

Certified to ISO 9001.

### Plus points

#### For the trade

- Just **one** body for all types of fixing.
- Low inventory costs and minimal stocking requirement thanks to unit packs for closer body and accessories.

#### For the fabricator

- Can be used for double action doors, or left and right hand single action doors.
- Installation and setting adjustment possible before fixing the doorset on site.
- No floor preparation necessary.
- Positive "zero" position for double action doors – easy to adjust.
- Comprehensive range of accessories.

#### For the architect/specifier

- Aesthetically impressive solution – especially with toughened glass doors.
- Ideal for shopfitting applications.

#### For the user

- No cluttering of door or floor appearance.
- Backcheck to prevent door contact with the frame.
- Smooth closing with adjustable closing speed.

Technical Data		RTS 85		
		EN 3	EN 4	EN 5
Closing force				
Internal doors up to and external doors <sup>1)</sup>	950 mm	●	–	–
	1100 mm	–	●	–
	1250 mm	–	–	●
Same model for double action doors, RH (ISO 5) and LH (ISO 6)		●	●	●
Closing speed variable by valve adjustment		●	●	●
Final closing speed variable by valve adjustment		●	●	●
Backcheck, progressive, mechanical		●	●	●
Backstop, mechanical		●	●	●
Hold-open	105°	○	○	○
	190°	○	○	○
Extended spindle	005 mm	○	○	○
	010 mm	○	○	○
Reduced pivot point for tempered glass doors (65 mm)		○	○	○
Weight in kg		4.7	4.8	4.9
Dimensions in mm	Length	323	323	323
	Width	90	90	90
	Height	38	38	38
Door closer tested to EN 1154		●	●	●

● Yes – No ○ Option

<sup>1)</sup> Max Door weight 110 kg

For applications involving particularly heavy or wide doors, and doors which have to close against wind resistance, the next highest door closer size should be selected.

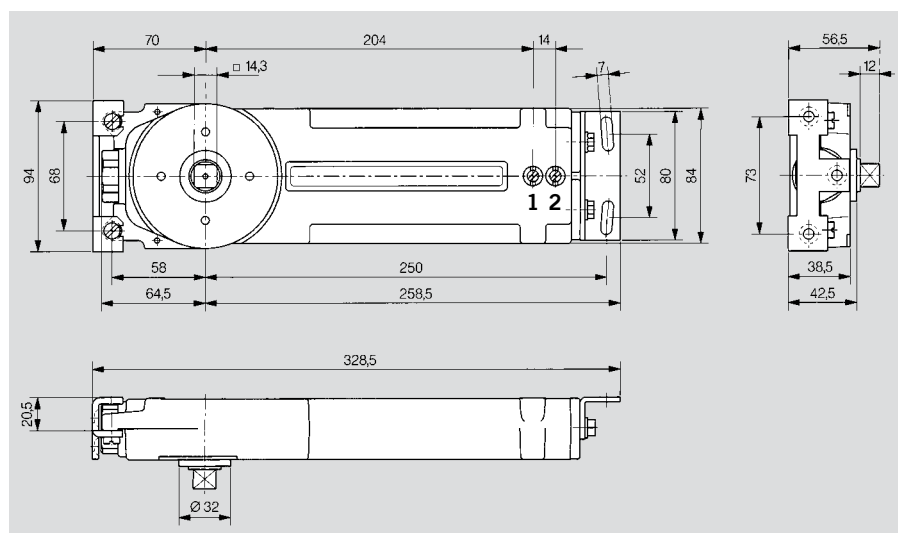
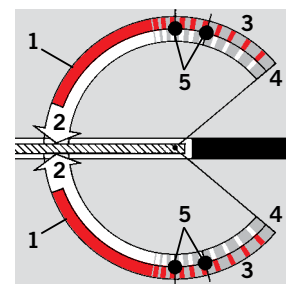

### Standard and optional functions

- 1 Fully controlled closing with adjustable speed
- 2 Adjustable final closing
- 3 Progressive mechanical backcheck
- 4 Mechanical backstop\*\*
- 5 Hold-open points – depending on model (optional) 105° or 90°

\*\* Door opening angle max. 130° on both sides; in the case of heavy doors which can be opened further, door stops must be used. In the case of single action doors, the opening angle may be reduced depending on the door design.

**Typical applications**

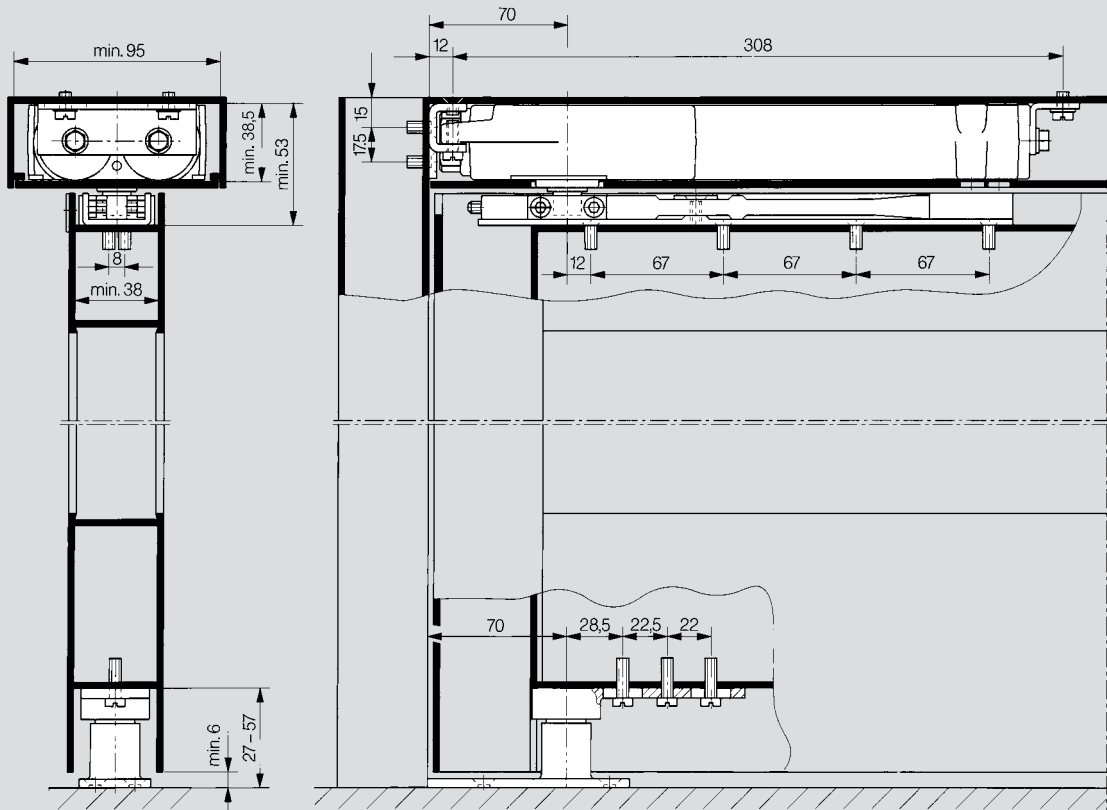

**Double action aluminium door**

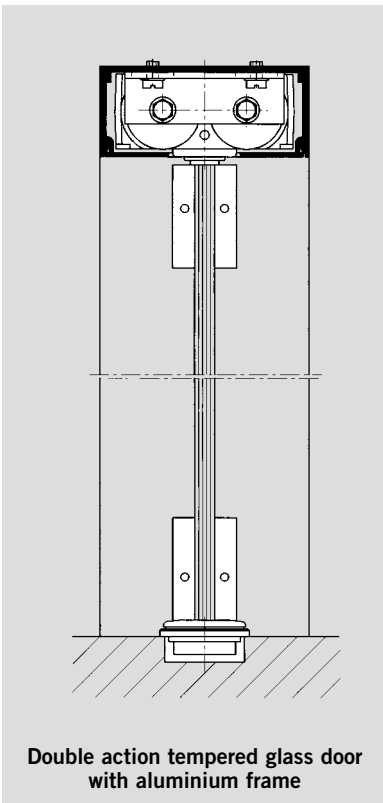

**Double action tempered glass door with aluminium frame**

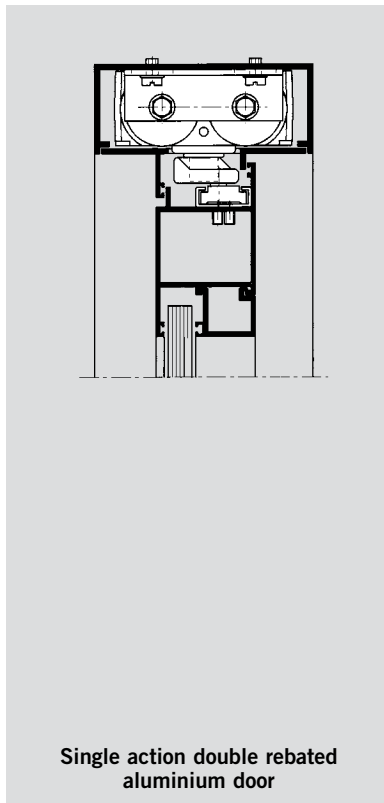

**Single action double rebated aluminium door**

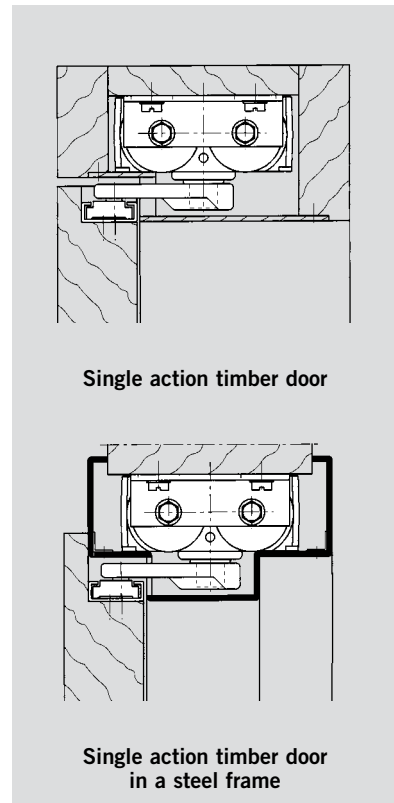

**Single action timber door**

**Single action timber door in a steel frame**

Detailed installation drawings on a scale of 1:1 will be provided on request.

**Accessories for double action and centre pivoted single action doors (70 mm pivot point)**
**Side-load installation**

Side-load installation is achieved by offering the door in the closed position, onto the floor pivot. The closer arm, fitted in the upper door rail, is connected to the spindle and secured with a clamping piece.

**1 Closer arm with arm channel**

Art.-No. 8530  
for top rails with min. 15 mm channel depth and 38 mm width.

**2 Floor pivot set, total height 27 mm**

Art.-No. 8550  
for bottom rails with channel depth of 18–20 mm. Floor portion of pivot is fitted directly to floor.

**Floor pivot set, total height 57 mm**

Art.-No. 8551  
for bottom rails with channel depth of 18–50 mm. (Floor portion may be shortened to suit bottom rail.)  
Floor portion of pivot is fitted directly to floor.

**3 Threshold pivot set**

Art.-No. 8554  
for bottom rails with channel depth of 25 mm. Floor clearance: 5 mm. Floor portion is fitted directly to threshold. (Upper portion same as 2).

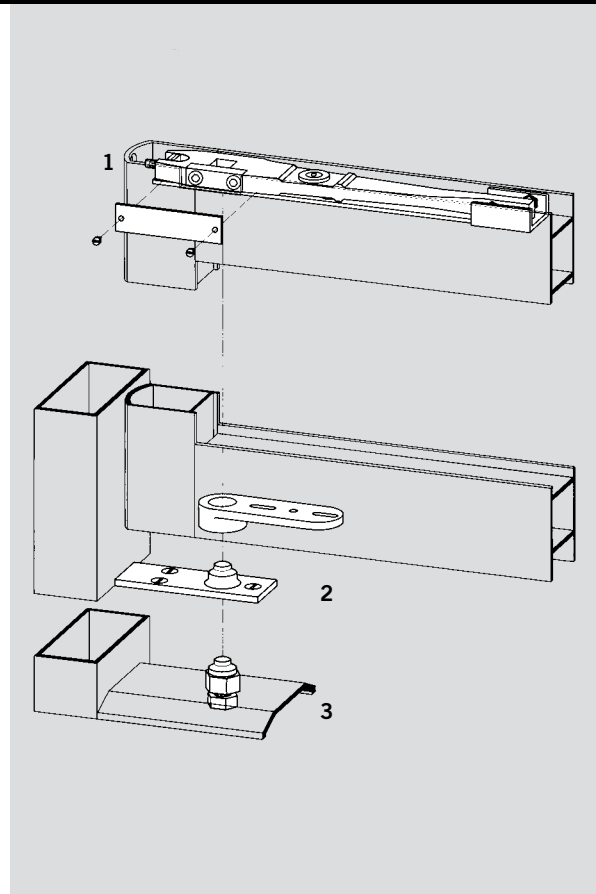
**End-load installation**

End-load installation is achieved by offering the door, in the open position, onto the floor pivot and spindle simultaneously. The floor pivot locks automatically, connection to spindle is secured with a clamping piece.

**1 Closer arm with arm channel**

Art.-No. 8534  
for top rails with min. 21 mm channel depth and 35 mm width.

**2 Floor pivot set, total height 27 mm**

Art.-No. 8552  
for bottom rails with channel depth of 18–20 mm. Floor portion of pivot is fitted directly to floor.

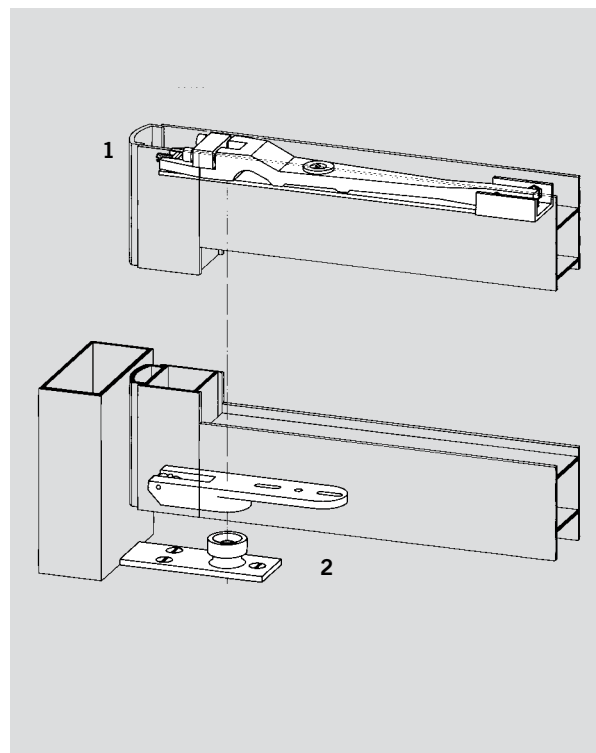

### Accessories for butt hung or offset pivoted single action doors

Single action doors hung on butt hinges or offset pivots can be connected to the closer with slide arm and channel assemblies. Please note that this application may reduce the maximum opening angle available on the door. Similarly, if a hold-open model has been selected, the hold-open

point will be altered: eg instead of 105°, the position will lie between 90° and 100°, depending on door thickness.

**Note:**  
Maximum door opening with slide arm and channel assemblies –105°. Consult our Technical

Service Department giving specific details for slide arm and channel assemblies. Drawings of door and frame details must be submitted together with the pivot centre of the hinge.

**1 Slide arm and channel**  
Art.-No. 8510

**2 Weld-on extension**  
Art.-No. 8521  
For steel doors, 40 mm long (can be shortened), 38 mm dia.

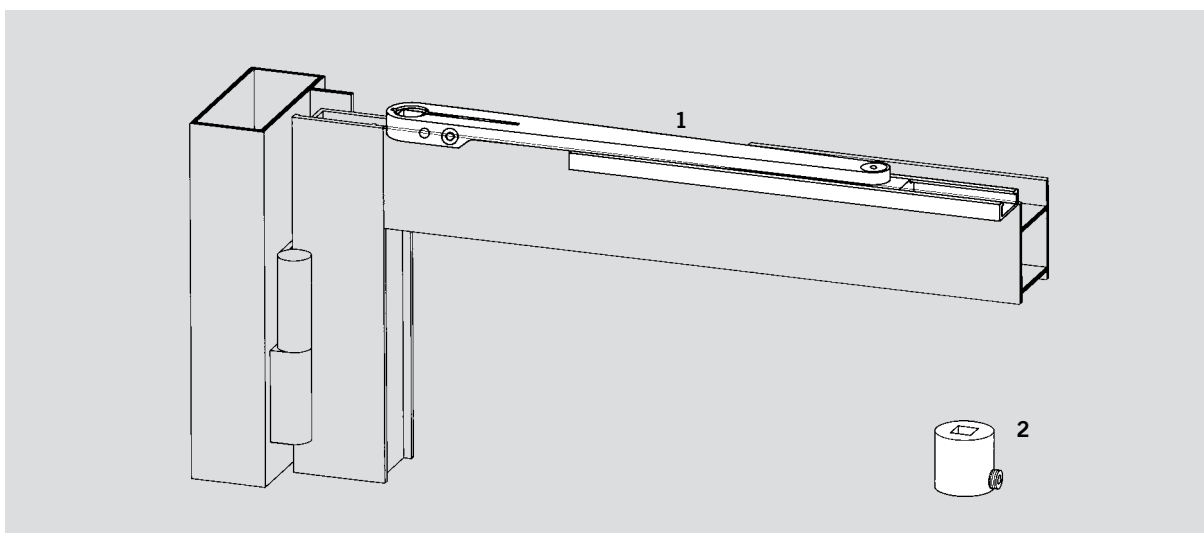

### Accessories for tempered glass doors (65 mm pivot point)

For tempered glass doors, the RTS 85 is used with a special fixing bracket, Art.-No. 8520 G, giving a 65 mm pivot point. The standard patch fittings can thus be used with appropriate inserts. (Patch fittings with insert available from DORMA-Glas range of products).

**1 Fixing bracket**  
Art.-No. 8520 G  
For fixing the DORMA RTS in the transom.

**2 Floor pivot bearing with flat-tapered spindle**  
Art.-No. 8560 G  
With sealed roller bearing assembly, rust-protected, for max. door weights of 110 kg. The floor pivot bearing combined with appropriate bottom straps from the accessories range for DORMA BTS floor springs is also suitable for aluminium, steel and timber doors.

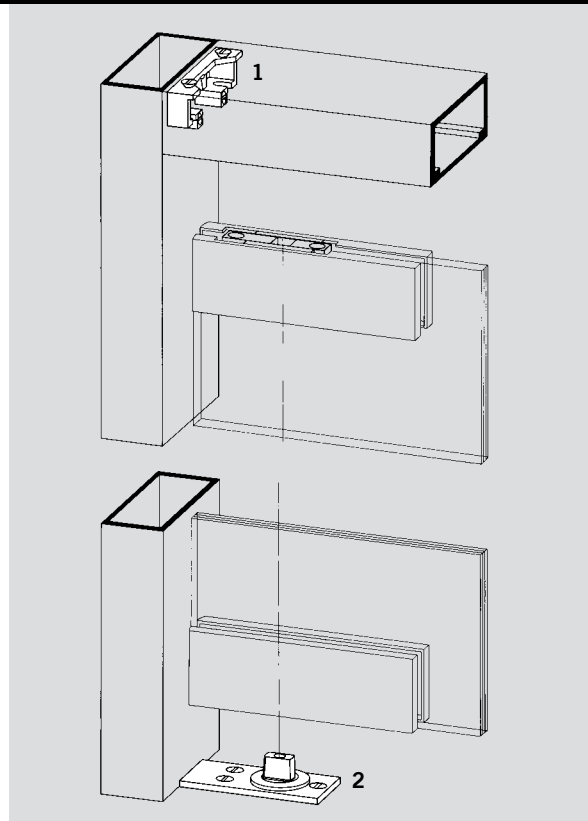

**DORMA RTS 85 for double and single action doors**

Door closer RTS 85	Standard model	Standard model with hold-open	Standard model with hold-open	with spindle insert 5 mm extended	with spindle insert 5 mm extended and at 105°	with spindle insert 5 mm extended and at 90°	with spindle insert 10 mm extended	with spindle insert 10 mm extended and at 90°
EN 3	85311101	85313101	85312101	85311102			85311103	85312103
EN 4	85321101	85323101	85322101	85321102	85323102	85322102	85321103	85322103
EN 5	85331101	85333101	85332101	85331102			85331103	85332103

Accessories	closer arm with bracket	Floor pivot set, height 27 mm	Floor pivot set, height 57 mm	Threshold pivot set 1"		Closer arm with channel for single action doors	weld-on extensions
Side-load installation	85210005	65310300	65410300	65510400		85210001	85110001
End-load installation	85210009	65320300					

**DORMA RTS 85 for tempered glass doors**

Door closer RTS 85 G	Standard model	Standard model with hold-open 90°	with spindle insert 5 mm extended
EN 3	85311301	85312301	85311302
EN 4	85321301	85322301	85321302

Accessories	Floor pivot set	Floor pivot set 5 mm extended	Floor pivot set 10 mm extended	Floor pivot set 15 mm extended	Floor pivot set stainless steel
zu RTS 85 G	65540000	85210025	85210026	85210027	65540059

**Specification text**

Transom concealed door  
closer with built-in cushion  
backcheck, adjustable  
closing speed and sweep  
range.

**Size**

- EN 3
- EN 4
- EN 5

**Model**

- For both single and  
double action doors  
(pivot point 70 mm)
- For tempered glass doors  
(pivot point 65 mm)

- Non hold-open
- Hold-open at 105°
- Hold-open at 90°
- With spindle insert 5 mm  
extended
- With spindle insert  
10 mm extended

- Closer arm  
Art.-No. \_\_\_\_\_
- Floor pivot set  
Art.-No. \_\_\_\_\_

**Make:** DORMA RTS 85



[www.dorma.com](http://www.dorma.com)



0722 493 359 / 0726 399 819

[info@nextcraftke.com](mailto:info@nextcraftke.com)

Gate No. 95A  
Limuru Road, Parklands.

[www.nextcraftke.com](http://www.nextcraftke.com)