

UNITILE CALCIUM SULPHATE PANEL

EMBARK ON GREEN

WORKSPACE TRANSFORMATIONS



30
Years

_____ of
leadership
_____ and legacy



100 mn
sq. ft.
_____ of
workspaces
_____ transformed



15 mn
sq. ft.
_____ annual
production
_____ capacity

08
Offices



across
India _____



15k+
Clients
_____ across
the globe

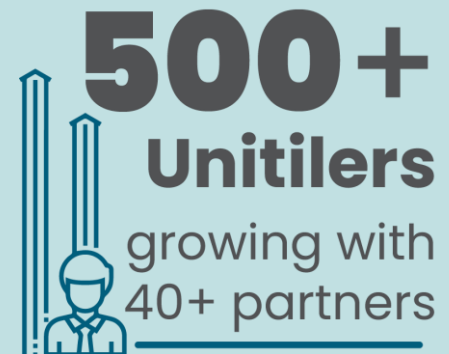

500+
Unitilers
growing with
40+ partners



Nextcraft Ltd.

www.nextcraftke.com

CERTIFICATIONS AND COMPLIANCE



World-class
quality



Environmental
conscientious
ness



Health
and safety
measures



Fire
certification
– Thomas
Belrite UK



Acoustics
– ARAI



Indian
Green
Building
Council



Singapore
Green
Building
Council
(SGBC)



Excellence
guaranteed
with third
party tested
at TÜV SÜD
PSB,
Singapore



Certified
by
Bureau
Veritas,
France

FEATURING UNITILE CALCIUM SULPHATE PANEL

Environmentally friendly panels for intelligent spaces

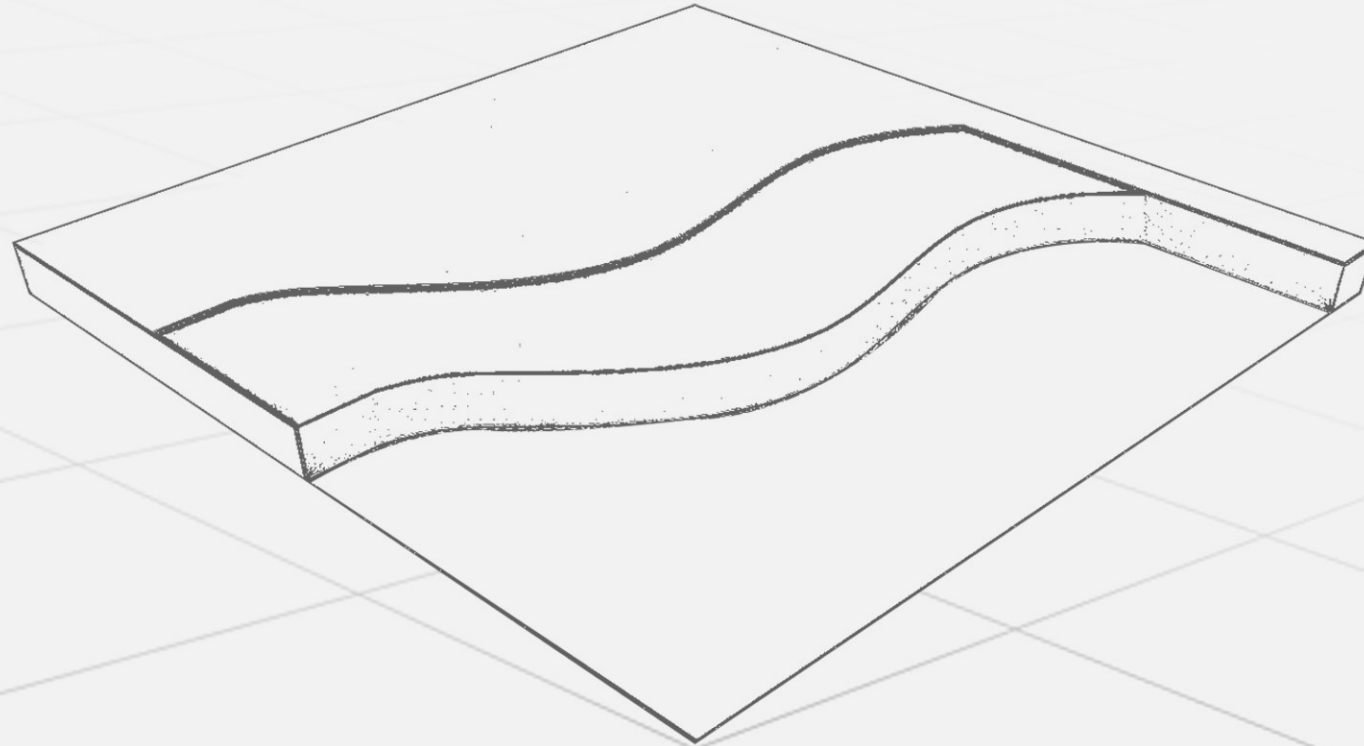

Made from calcium sulphate core, high-density of of natural gypsum. The edges of the panel are protected with a PVC edge band.

Dimensions: 600mm x 600mm

Panel Thickness: 28mm | 30mm | 32mm | 34mm

SYSTEM SELECTION GUIDE

Structural performance as per BSEN 12825	34 mm
Concentrated Load	625 Kgs (6.12 kN)
Ultimate Concentrated Load	1250 Kgs / 12.25 kN
Uniformly Distributed Load (As per PSA MOB PF 2 PS/ CISCA)	1875 Kgs / m ²
Stringer Load	102 Kgs (225 lbf)

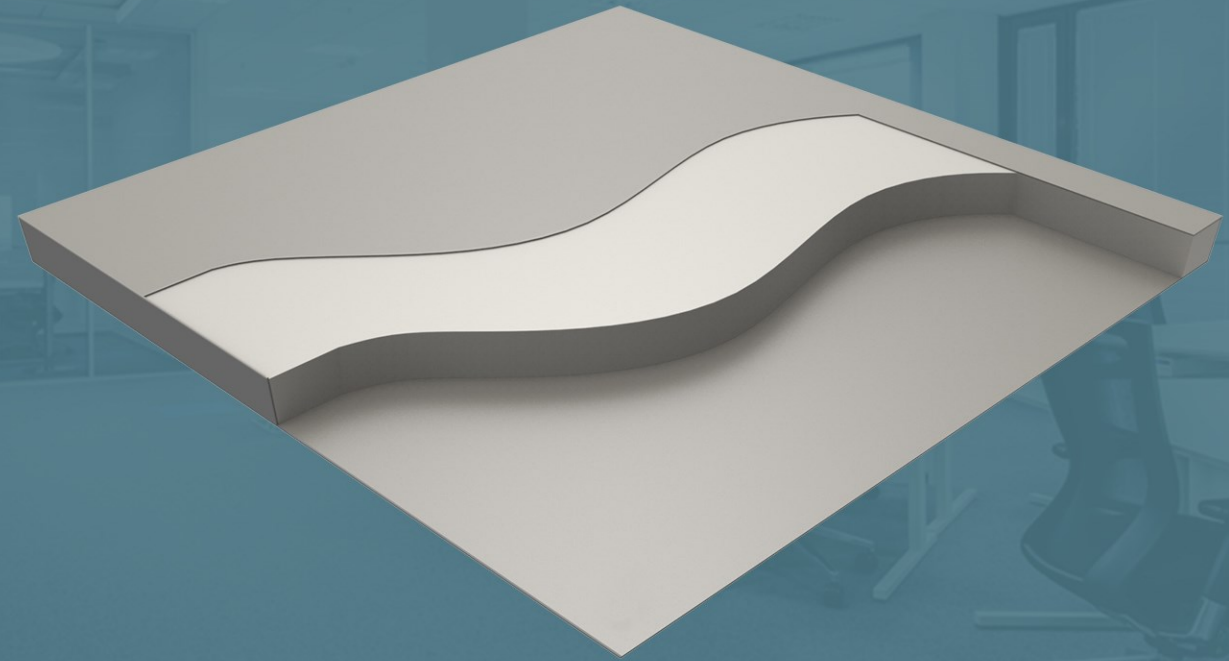

TOP AND BOTTOM FINISHES

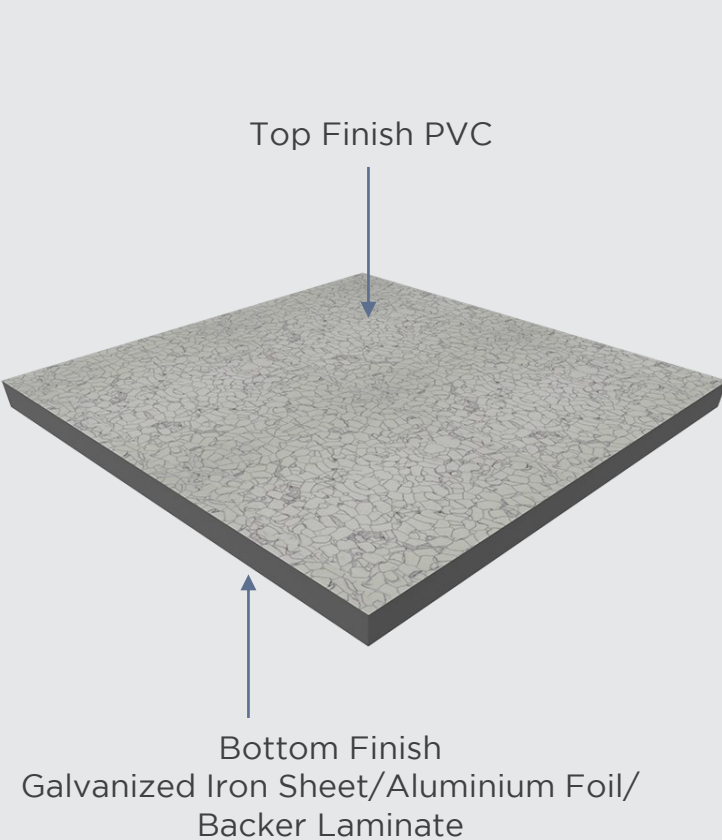
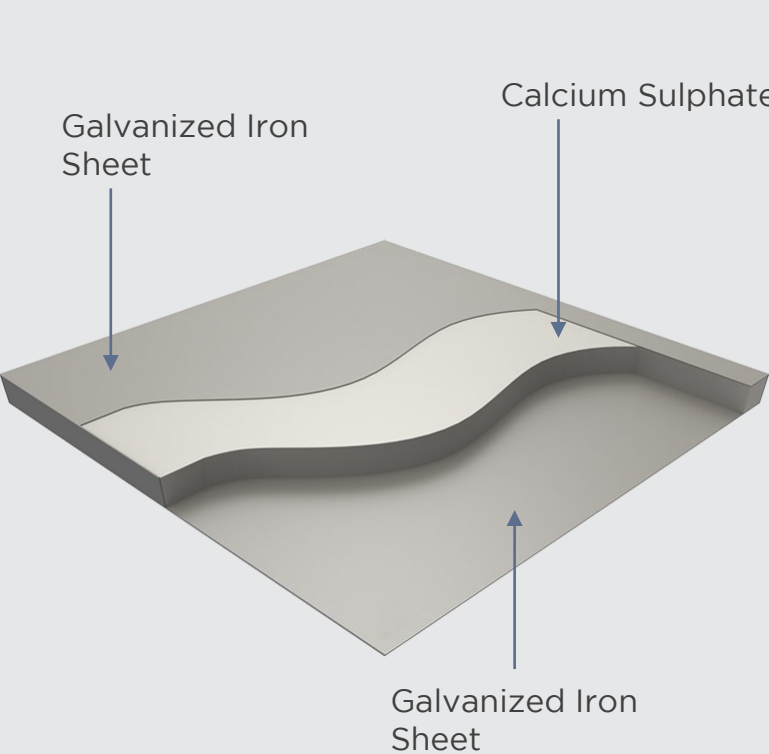

AVAILABLE EDGE BAND

Regular PVC
Edge Band

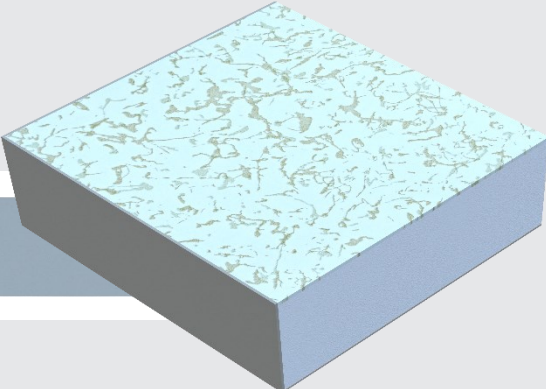

Profile PVC
Edge Band

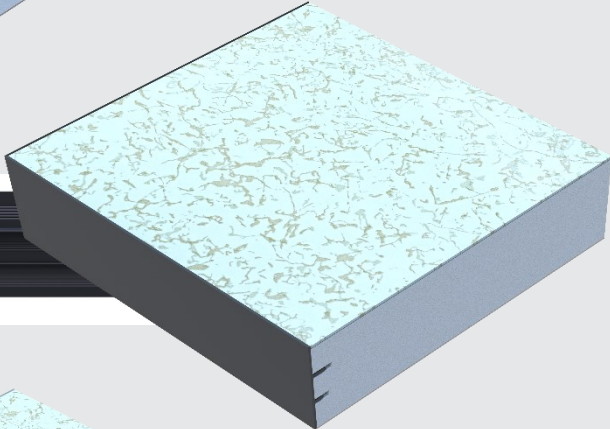
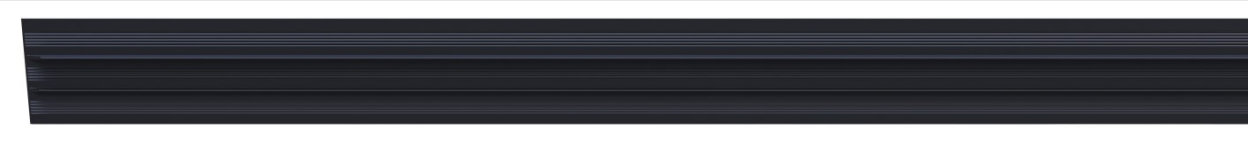

Aluminium
Edge Band

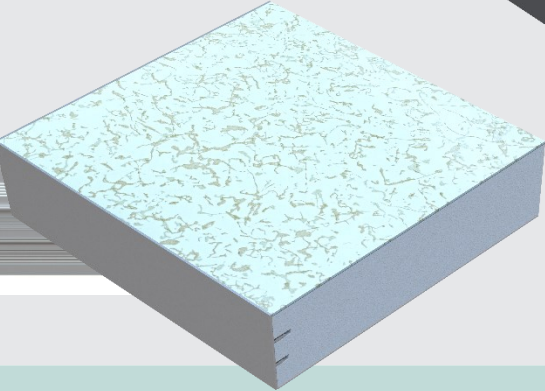
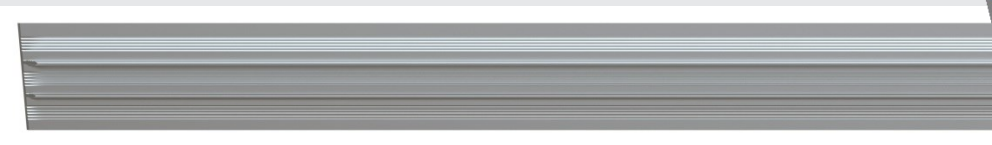

FEATURES ALUMINIUM EDGE BAND



Excellent bonding to the panel with 100% solid aluminum edge

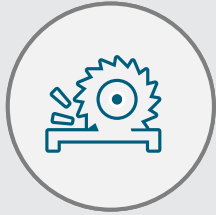

No debonding during cutting of field cut panels on site



Improves resistance to impact load during and after the construction program



Ensures conductivity 100%



Maximum resistance to damage by rolling load due to fully metal edges



Ensures easy and frequent removal without damaging the edges of the panel

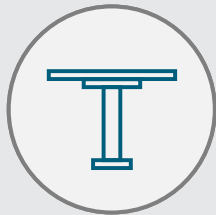

It compliments the sturdy panel locking system provided on the understructure



Fire resistant or high level of fire



Protects peripheral chipping of the laminate as the impact is taken by the Aluminum edge band



Corrosion resistant



Aesthetically appealing to end user

DESIGNED FOR NEW-AGE WORKSPACES

A better and conscious choice.

OPEN OFFICE

ACCESS FLOOR COMPONENTS

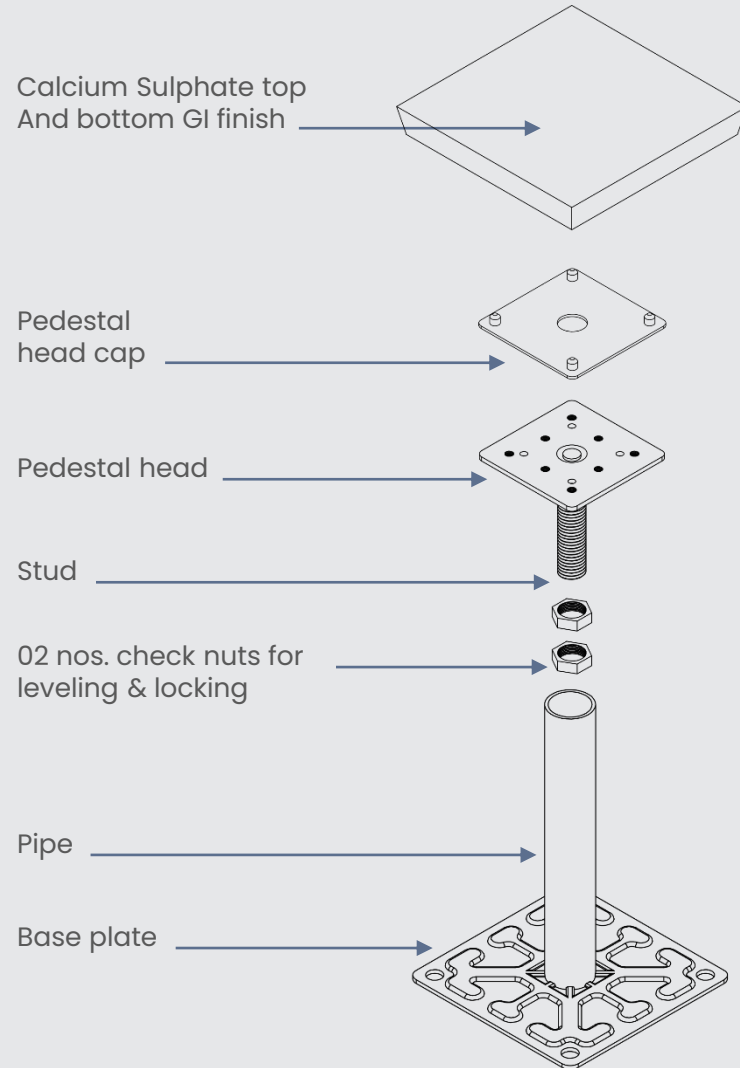

GRAVITY LAY SYSTEM

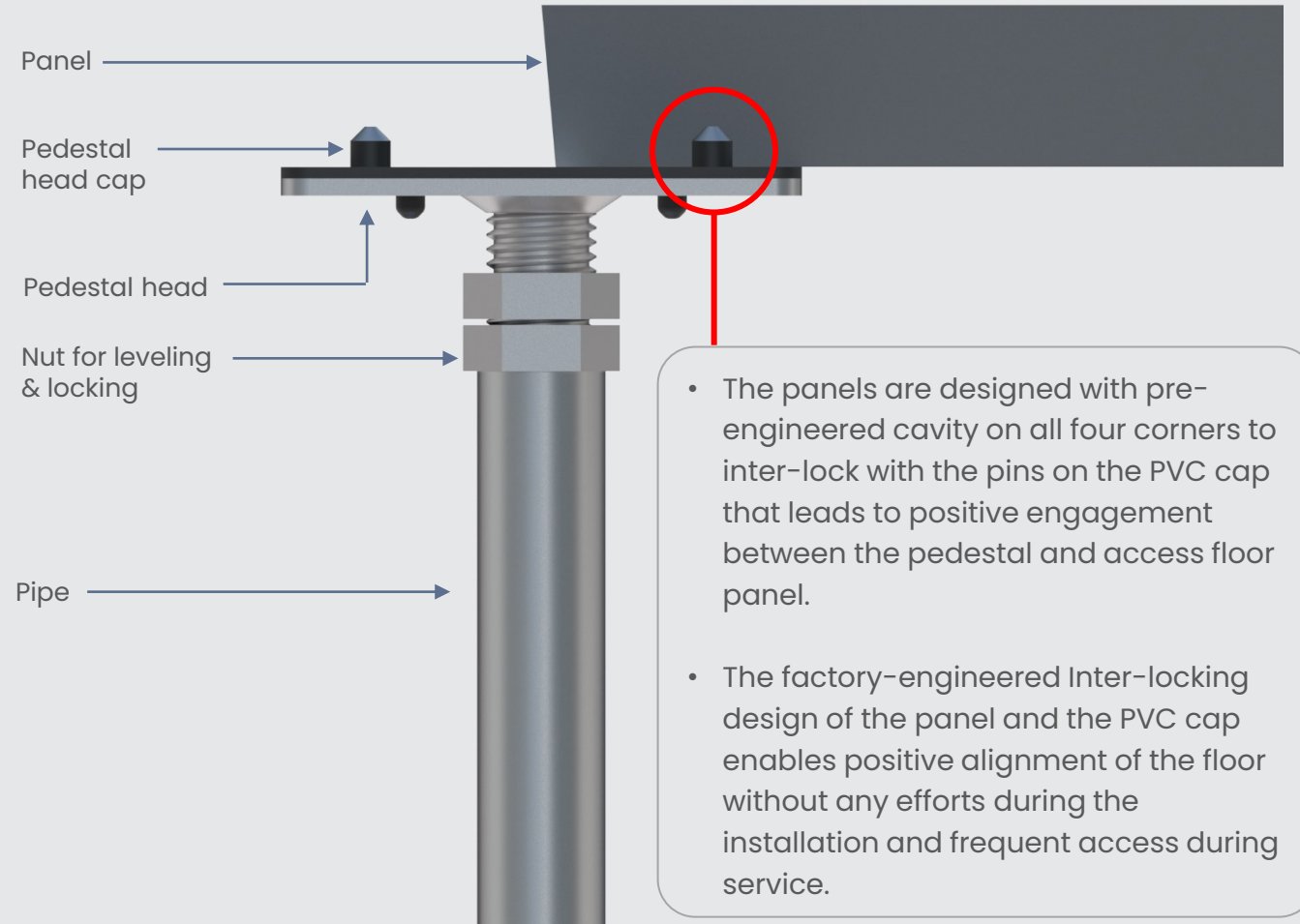

A FUTURE-PROOF DATA CENTER

that has the flexibility to remain at the technological
forefront

CRITICAL ROOM, DATA CENTER & CONTROL ROOM

ACCESS FLOOR COMPONENTS

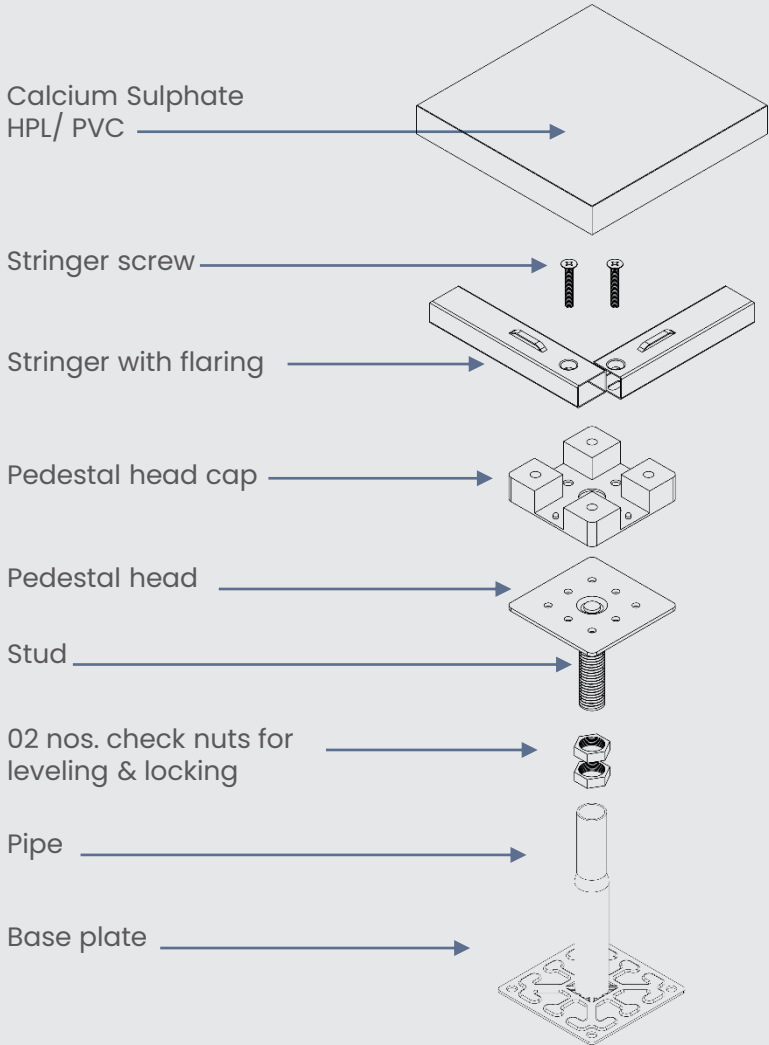

EDGE SUPPORT RIGID GRID (ESRG) SYSTEM

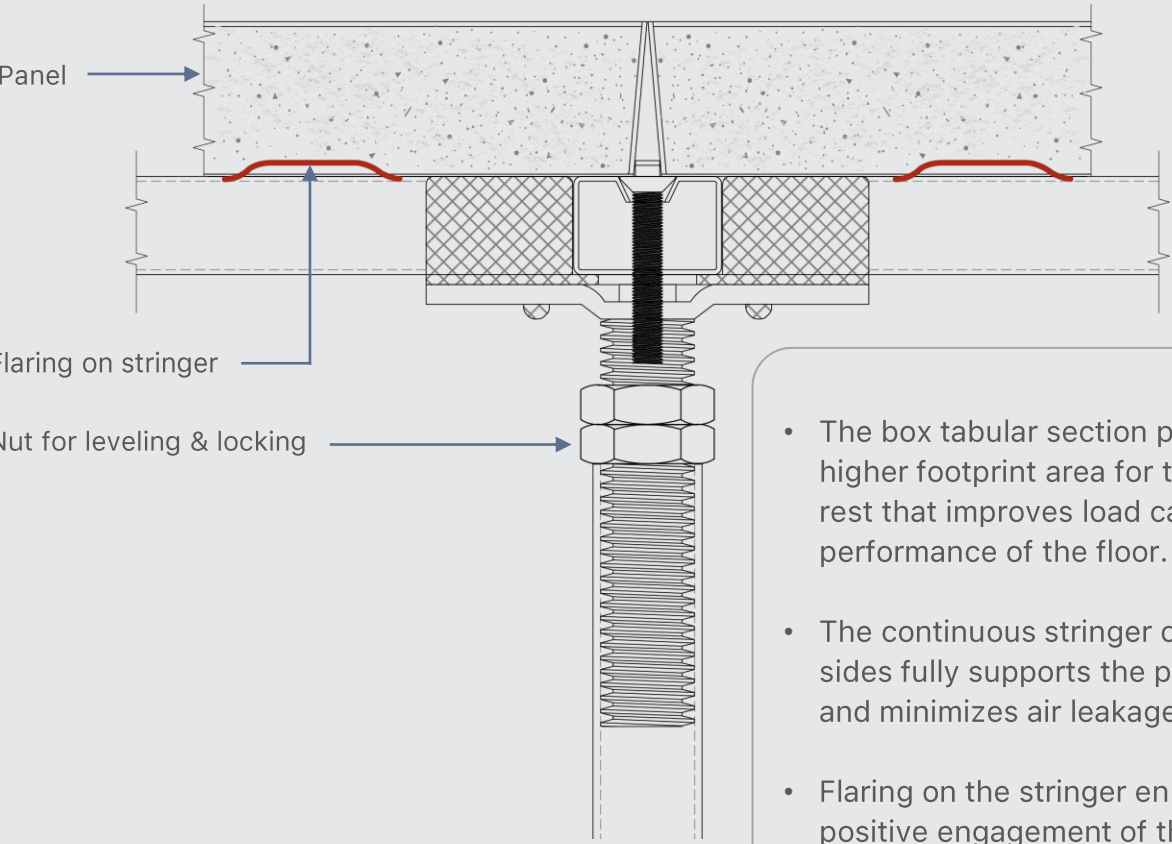

- The box tabular section provides a higher footprint area for the panel to rest that improves load carrying performance of the floor.
- The continuous stringer on both sides fully supports the panel edges and minimizes air leakage.
- Flaring on the stringer enhances positive engagement of the access floor panel

BENEFITS AND ADVANTAGES



Excellent acoustic properties
and dissipates electrical
charges



Excellent fire resistance
properties tested as per Class
O and Class 1 standards

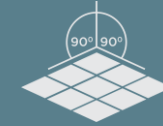

Precision in floor levels and
positive alignment with the
understructure



High strength
to weight performance

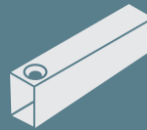

Unique
In-built stringer design



The calcium sulphate core of the
panels is recyclable using an
appropriate recycling method



OTHER APPLICATIONS

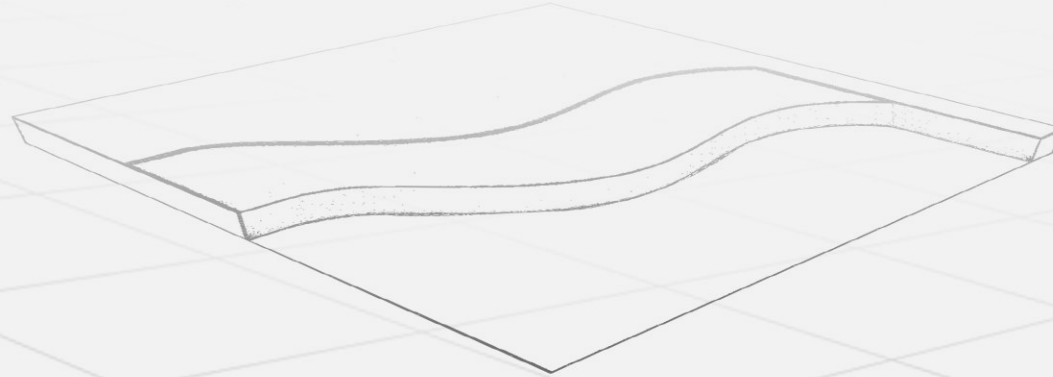

OPEN OFFICES

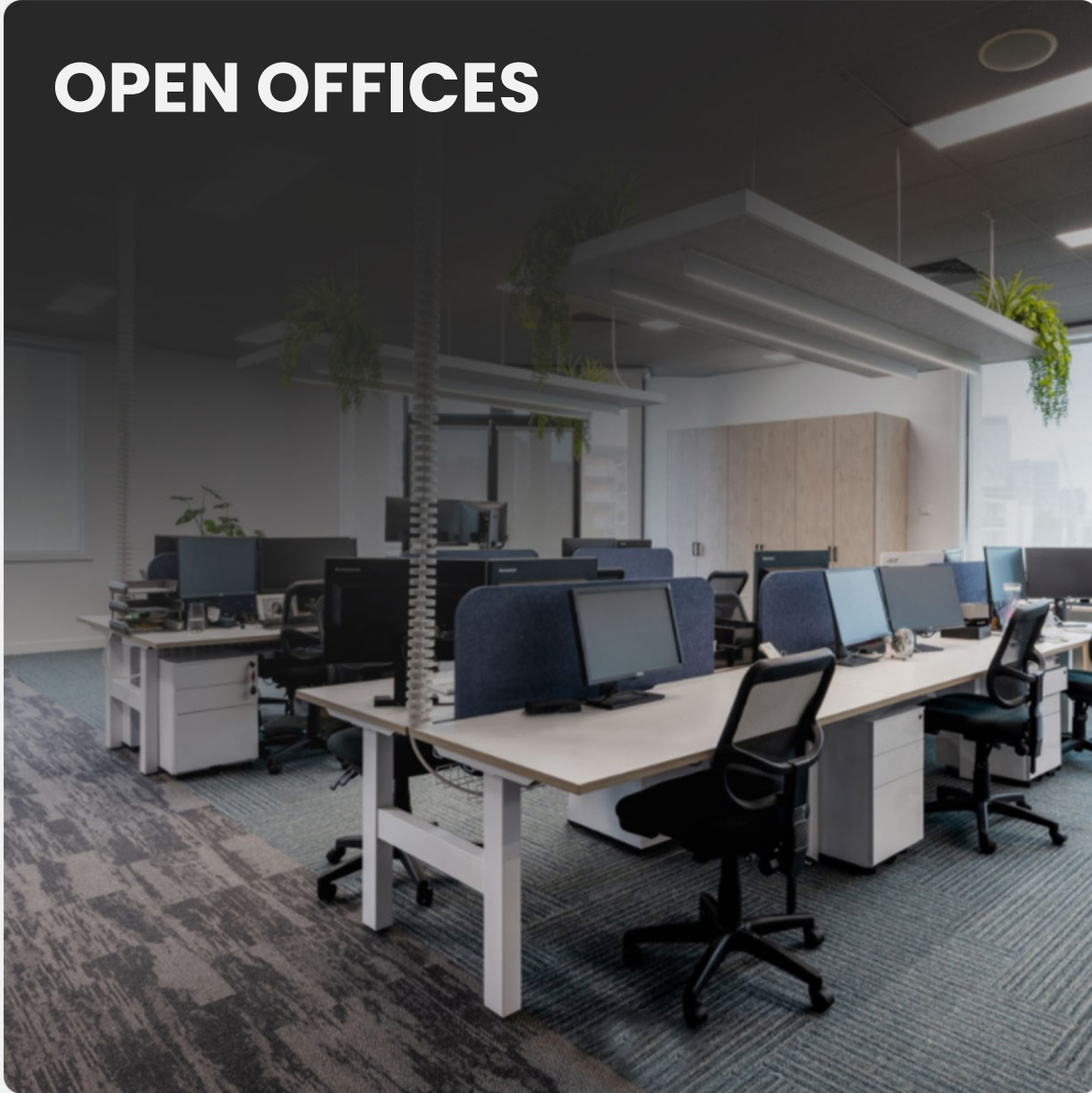

DATA CENTERS

- ◇ Communication Rooms
- ◇ Server Rooms
- ◇ Labs
- ◇ Process Interface Buildings (PIB)
- ◇ Rack Rooms
- ◇ Switch Rooms



EDUCATIONAL SPACES

- ◇ Classrooms
- ◇ Auditoriums
- ◇ Libraries
- ◇ Training Rooms



CONTROL ROOMS

- ◇ Network Operations Center (NOC)
- ◇ Supervisory Control and Data Acquisition (SCADA)



CASINOS

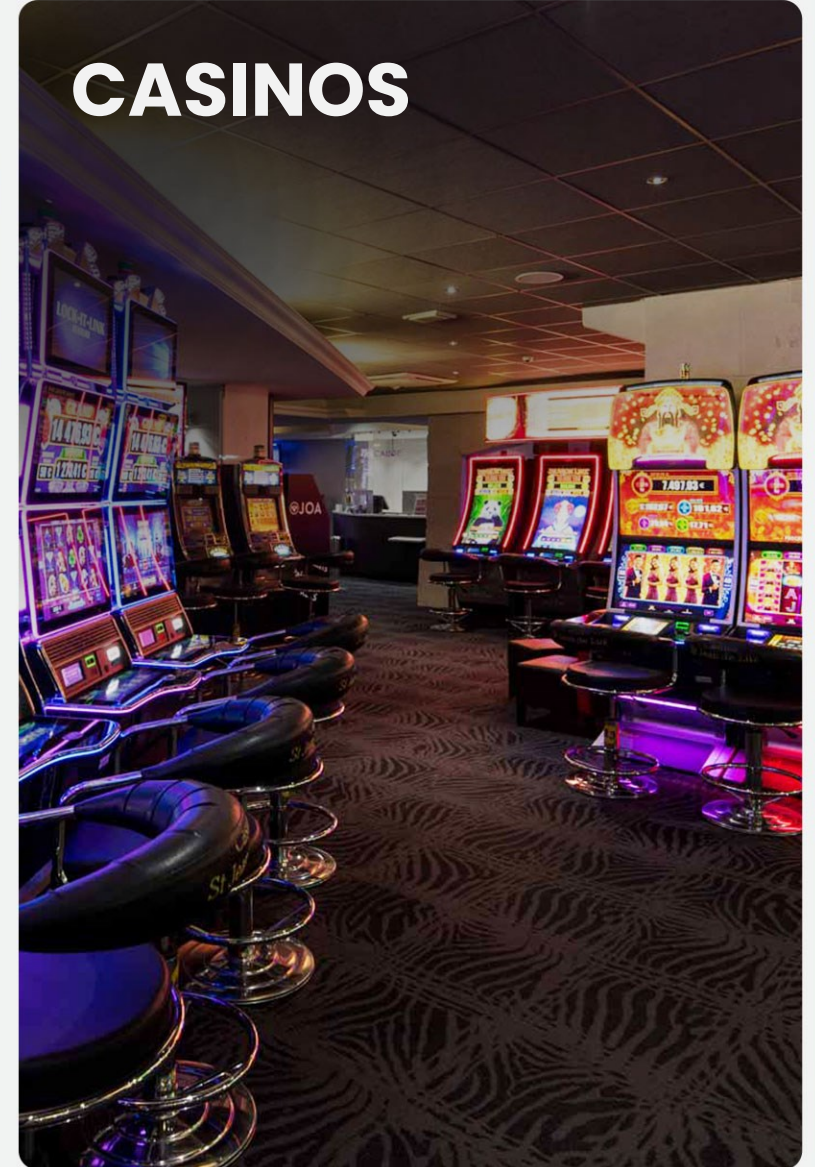



KEY PROJECTS

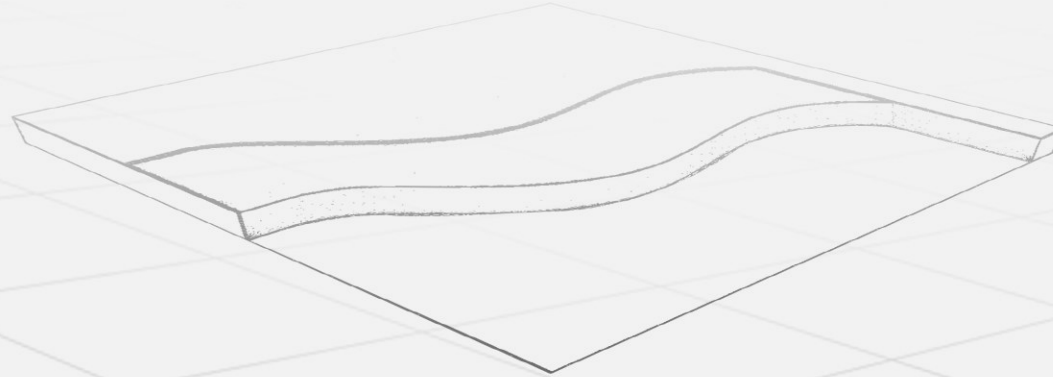

PROJECTS EXECUTED WITH UNITILE CALCIUM SULPHATE PANEL (UCS)

*Areas mentioned in sq. ft.



Mumbai, Nagpur
& Hyderabad
14,36,000



Navi Mumbai
& Mumbai
5,38,555



Navi Mumbai
2,36,248



Navi Mumbai
1,31,988



Bengaluru, Pune
Noida & Chennai
1,10,214



Chennai
64,595



Delhi & Gujrat
21,265



Ahmedabad &
Hyderabad
16,643

**AIR
FORCE
STATION**

Lucknow
11,291



Jabalpur
& Noida
5,763



New Delhi
4,801

**PRINTLINK
OCAC EAST**

Odisha
3,229

PROJECTS EXECUTED WITH UNITILE CALCIUM SULPHATE PANEL (UCS)

*Areas mentioned in sq. ft.



IndianOil

Cochin
2,806



TELANGANA FIBER GRID

Hyderabad
2,700



Mumbai
2,680

**BLOOM
DÉCOR
ENTERPRISE**

Bharuch
2,248



Chandigadh
1,722



Mumbai
1,292



Odisha
1,112



Kanpur
431



Bhopal
11,625

PYROTECH



beyond the obvious®

Udaipur
6,118



KEY CLIENTS

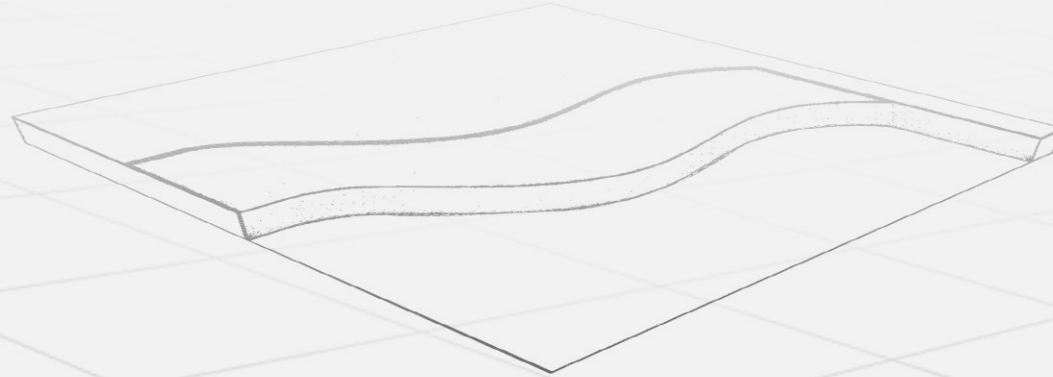

KEY CLIENTS



KEY CLIENTS

amazon



Gartner



Indiabulls
HOUSING FINANCE



NETFLIX



Network 18



MAERSK



THOMSON REUTERS



Bloomberg

Uber



ORACLE

Walmart



OUR PRESENCE



INDIA

Ahmedabad | Ankleshwar | Aurangabad | Bareilly | Bengaluru | Chandigarh | Chennai | Cuttack | Goa | Gurugram | Guwahati | Hyderabad | Indore | Jaipur | Kanpur | Kolkata | Lucknow | Mumbai | Nagpur | New Delhi | Pune | Raipur | Thane | Vadodara | Thiruvananthapuram | Cochin

INTERNATIONAL

Azerbaijan | Bahrain | Bangladesh | Egypt | Hong Kong | Indonesia | Kenya | Nepal | Oman | Philippines | Qatar | Saudi Arabia | Singapore | Sri Lanka | Tanzania | Turkey | UAE | Vietnam | Maldives | Nigeria | Bhutan | South Africa